

R1 used to measure input current.

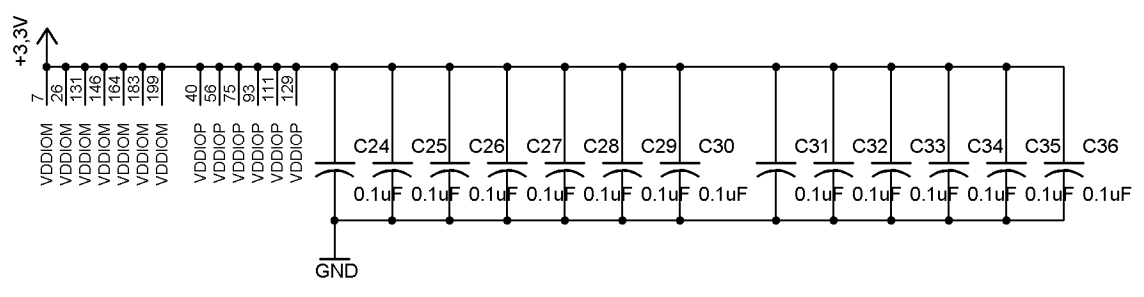

CPU, POWER, USB	
TITLE: KB9202C	
Document Number:	REV: c
Copyright 2006-2008, KwikByte (www.kwikbyte.com)	
Date: 10/07/2008 08:43:49a	Sheet: 1/6

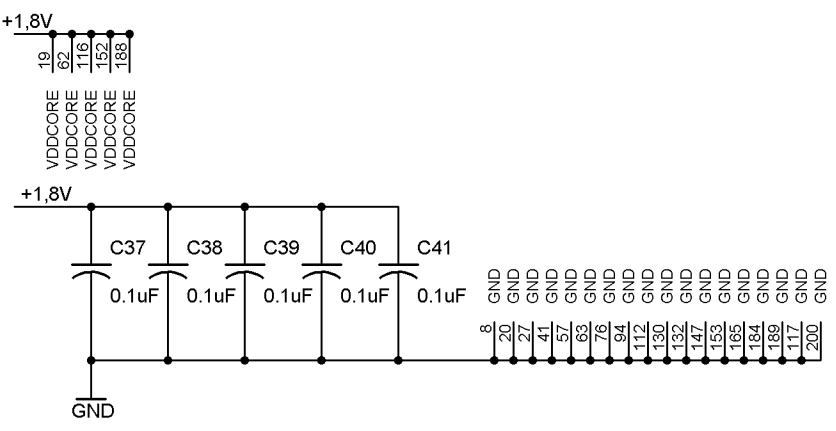
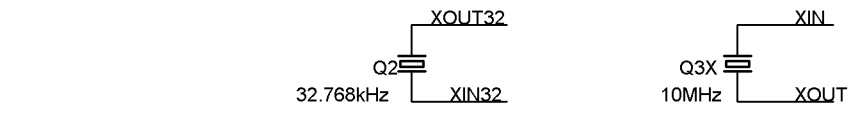
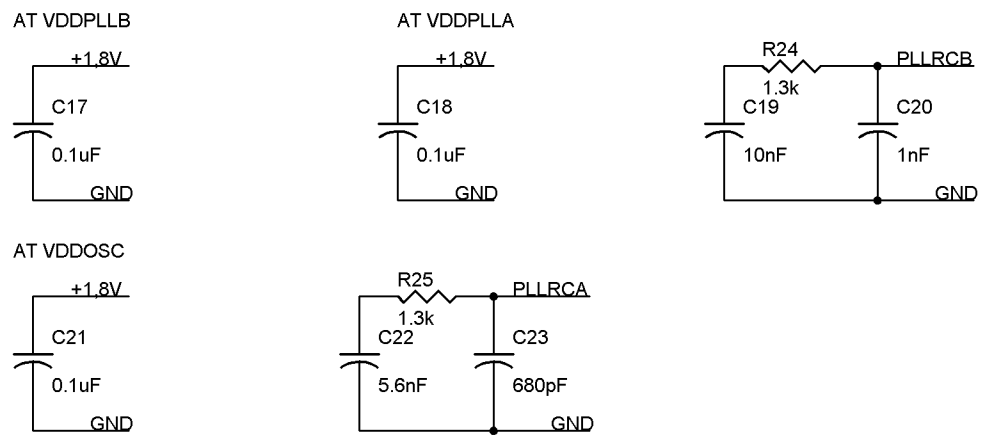
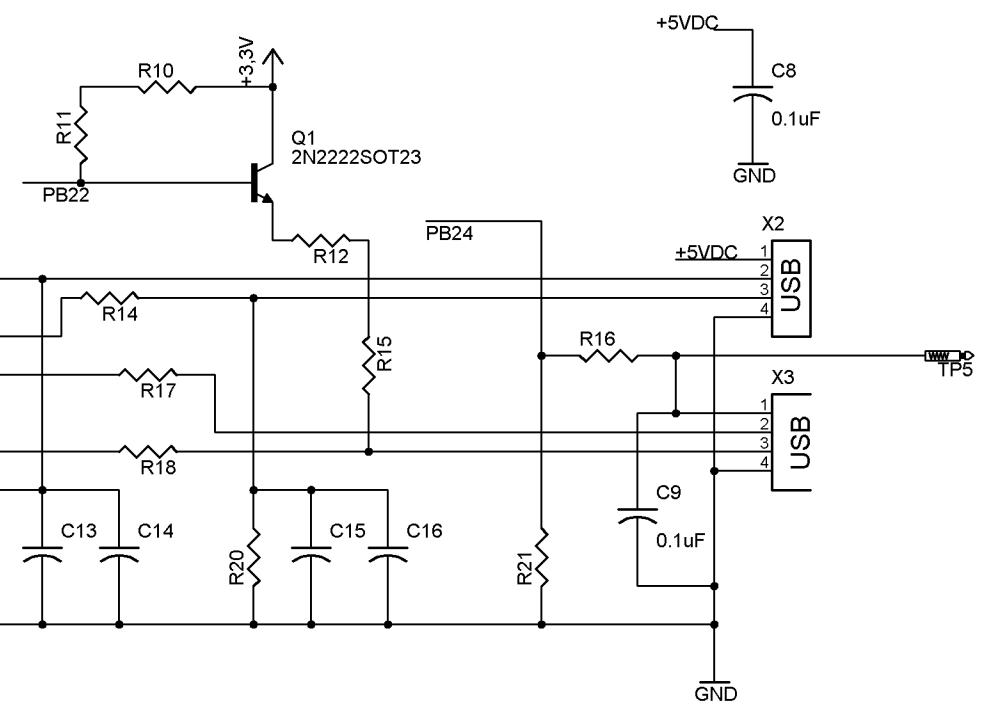
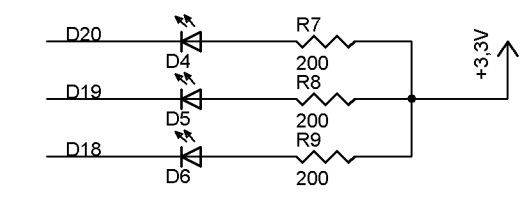
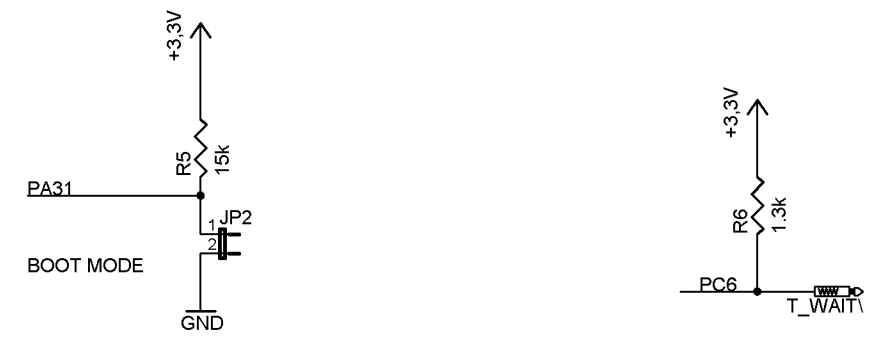
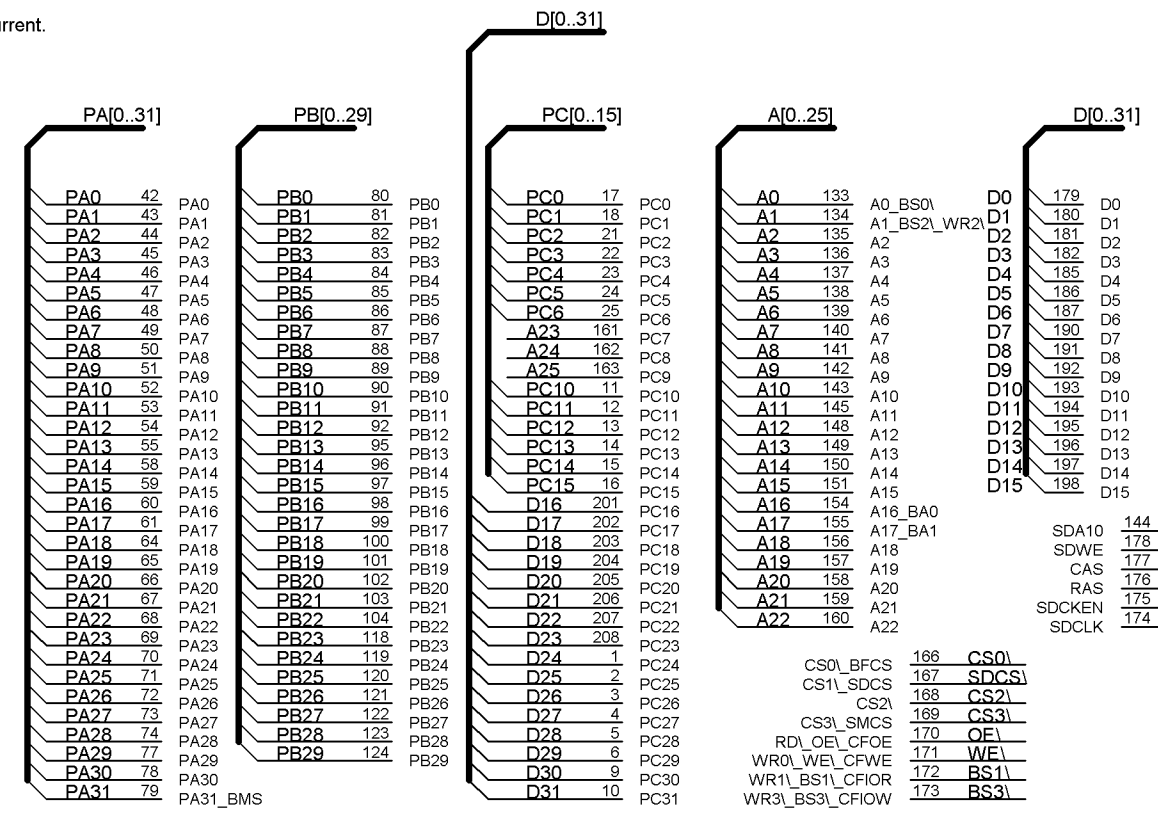
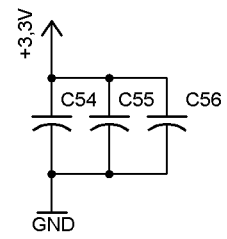
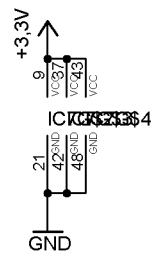
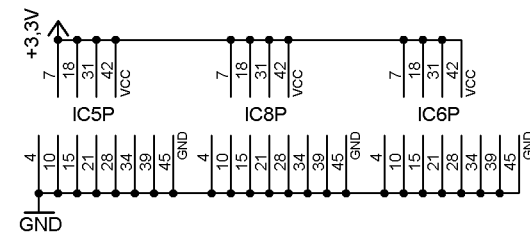
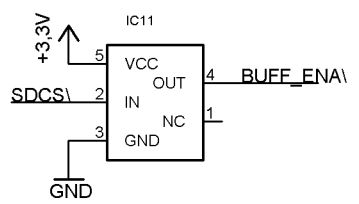
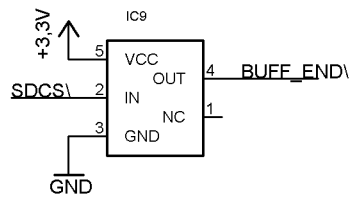
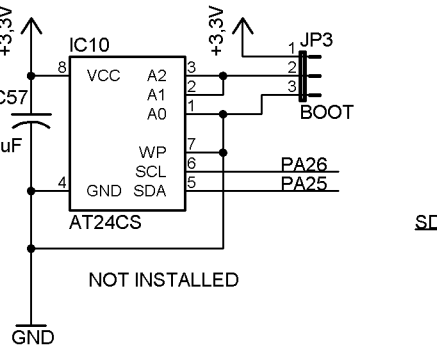
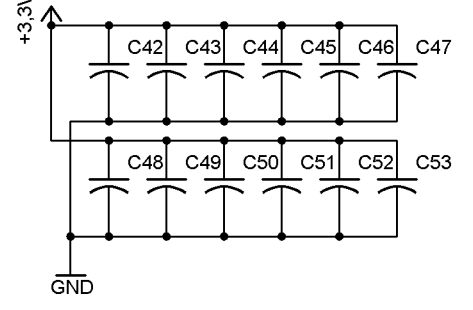
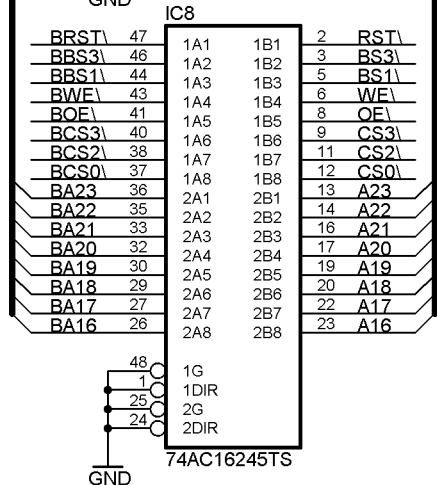
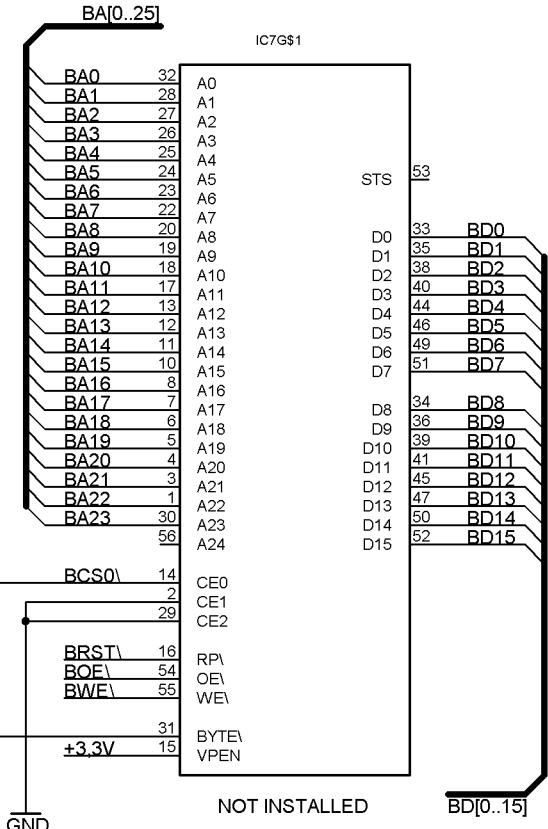
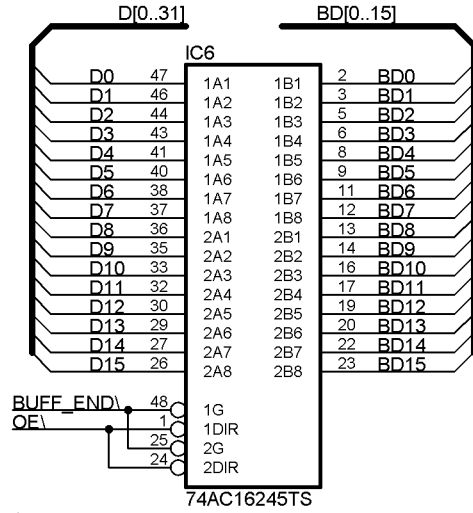
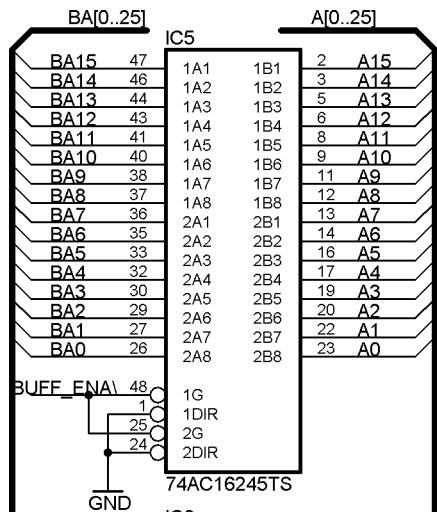

PARALLEL FLASH, BUFFERS, EEPROM	
TITLE: KB9202C	
Document Number: Copyright 2006-2008, KwikByte (www.kwikbyte.com)	
Date: 10/07/2008 08:43:49a	REV: C
Sheet: 2/6	

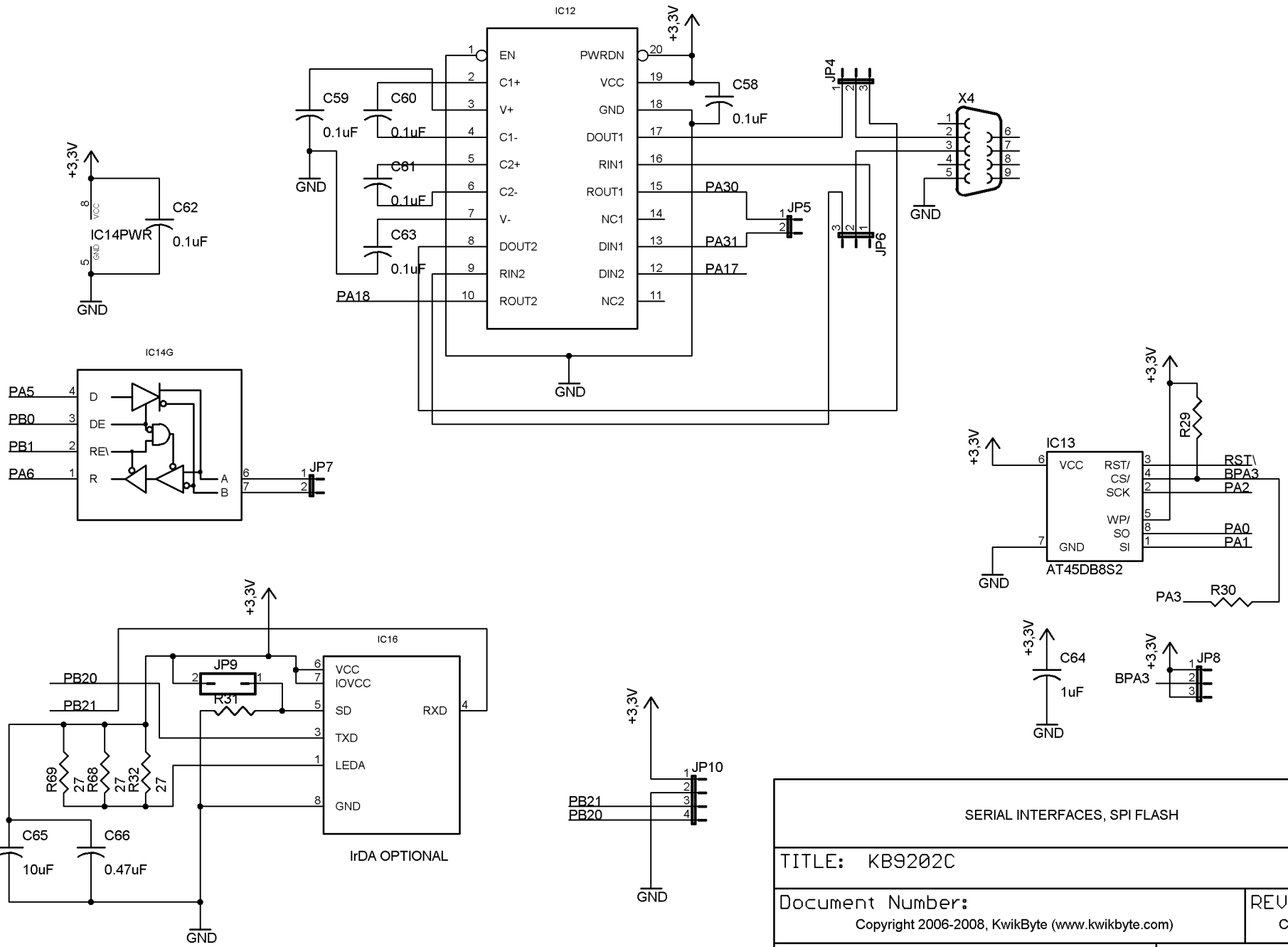

SERIAL INTERFACES, SPI FLASH	
TITLE: KB9202C	
Document Number: Copyright 2006-2008, KwikByte (www.kwikbyte.com)	REV: C
Date: 10/07/2008 08:43:49a	Sheet: 3/6

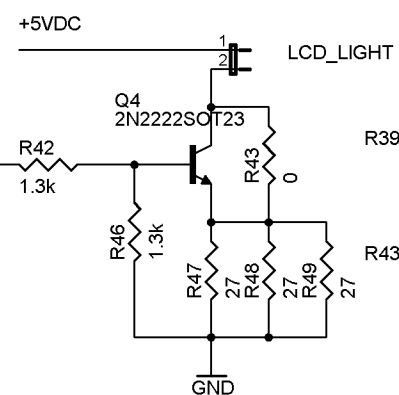
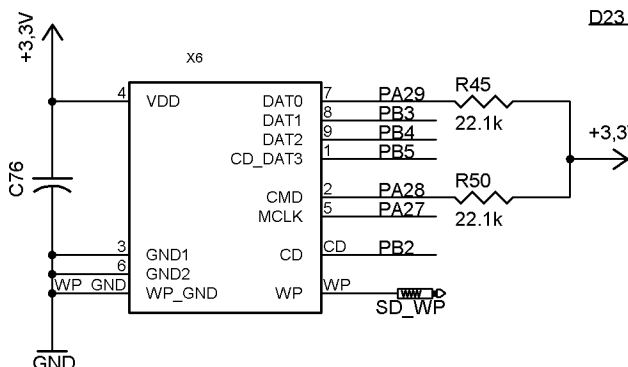
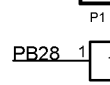
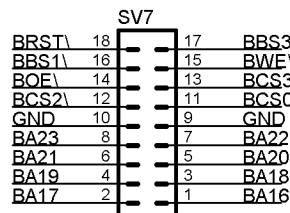
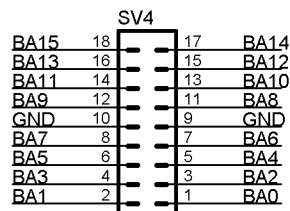
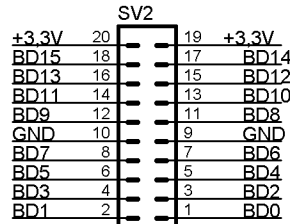
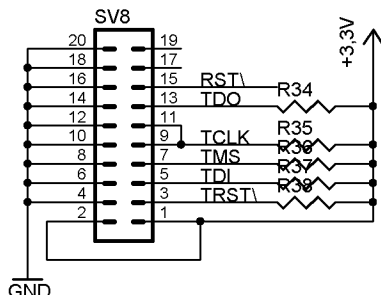
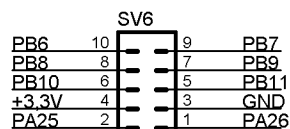
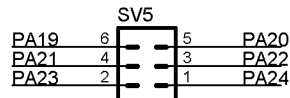
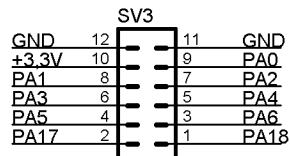
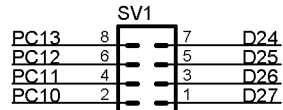

LCD OPTIONAL

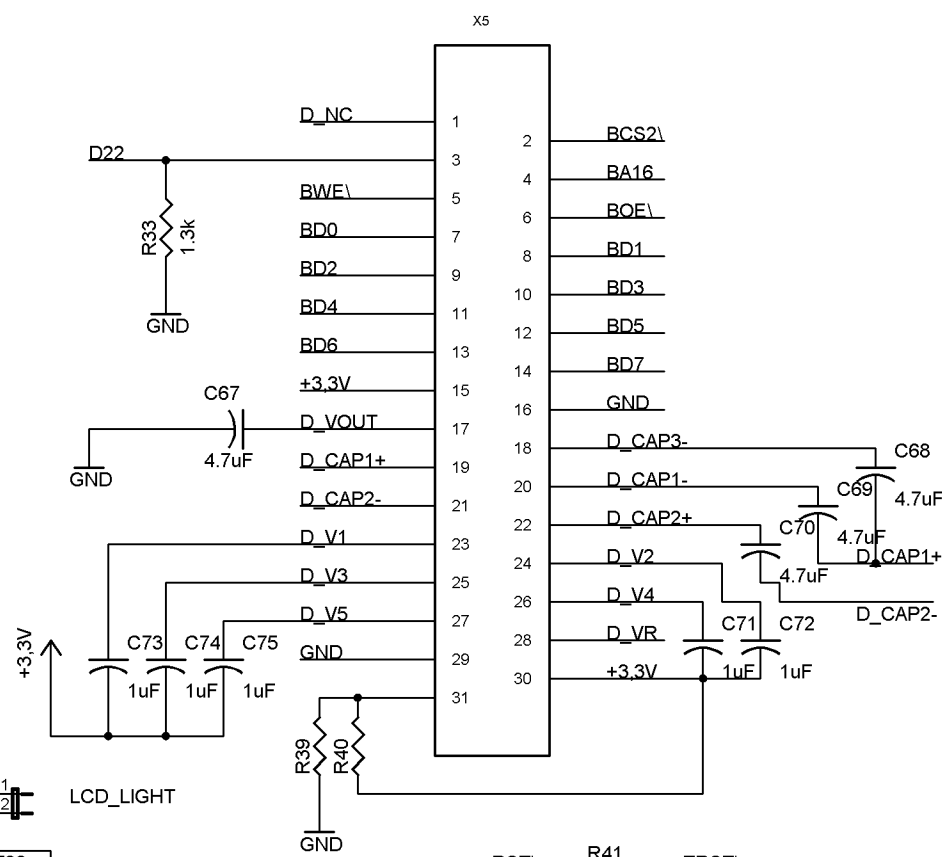

OFF-CARD CONNECTORS, SD CARD CONNECTOR, LCD CONNECTOR	
TITLE: KB9202C	
Document Number:	REV: C
Copyright 2006-2008, KwikByte (www.kwikbyte.com)	
Date: 10/07/2008 08:43:49a	Sheet: 4/6

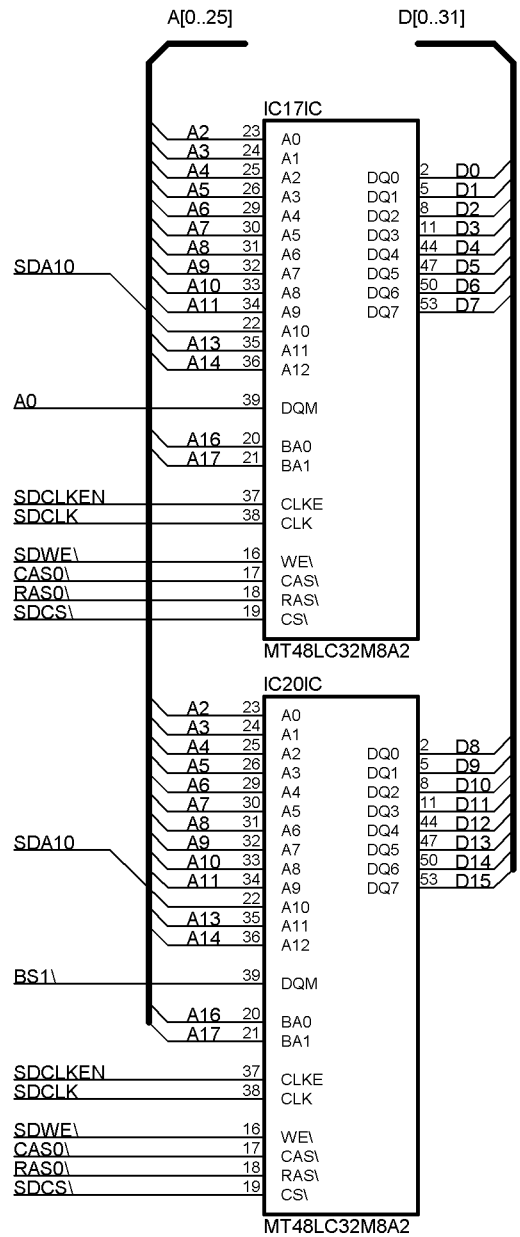

SDA10

A0

SDCLKEN  
SDCLK

SDWE\  
CAS\  
RAS\  
SDCS\

SDA10

BS1\

SDCLKEN  
SDCLK

SDWE\  
CAS\  
RAS\  
SDCS\

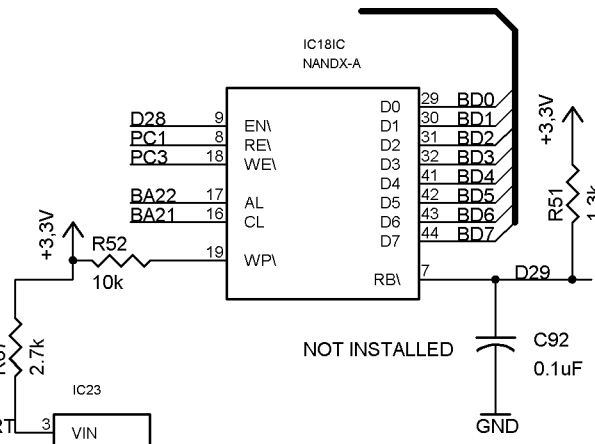
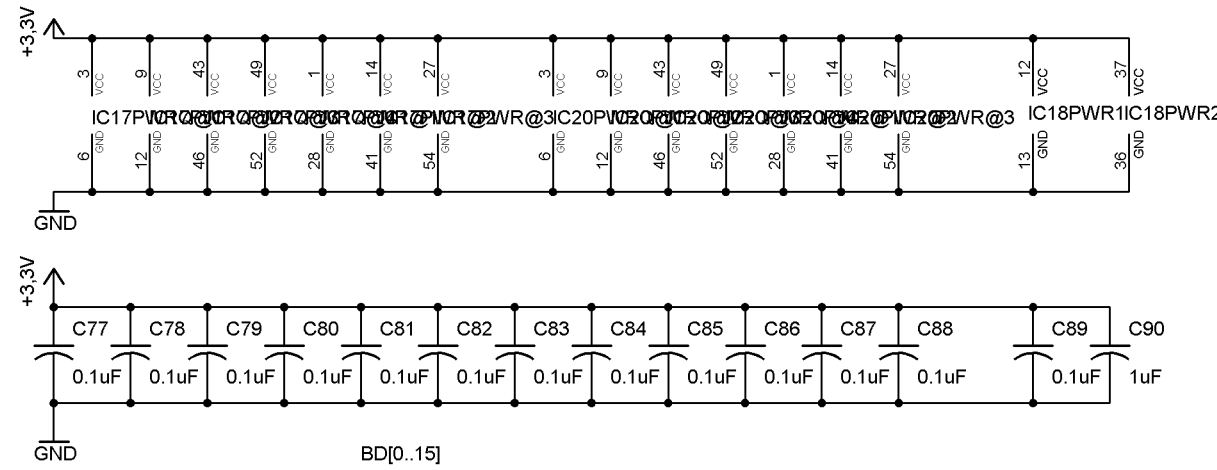

NOT INSTALLED

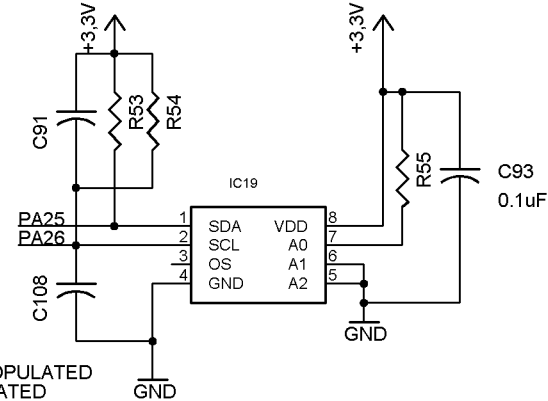
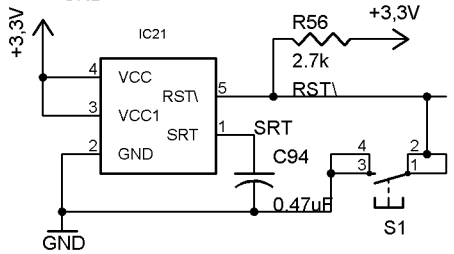

C91 NOT POPULATED  
IC21: IC23, R67 NOT POPULATED  
IC23: IC21 NOT POPULATED

SDRAM, NAND FLASH, RESET, TEMPERATURE SENSOR	
TITLE: KB9202C	
Document Number: Copyright 2006-2008, KwikByte (www.kwikbyte.com)	REV: C
Date: 10/07/2008 08:43:49a	Sheet: 5/6

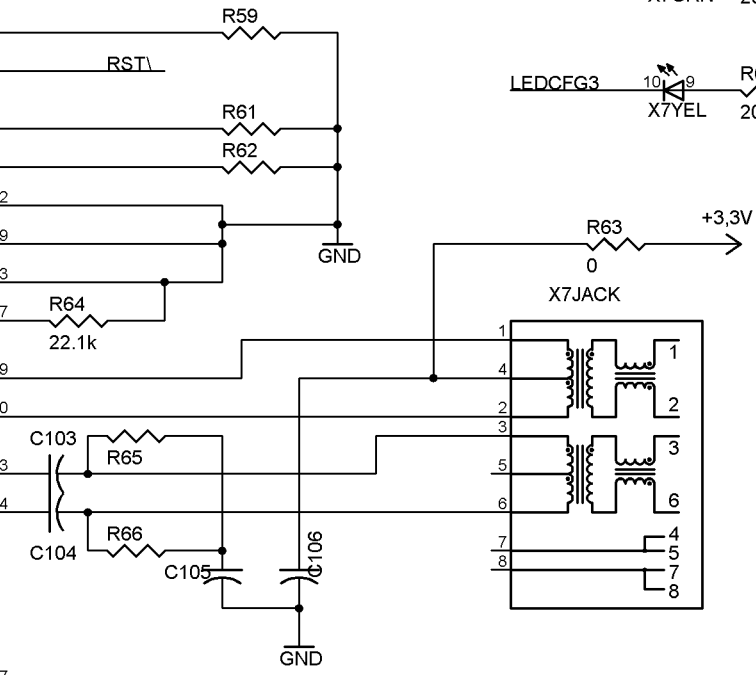
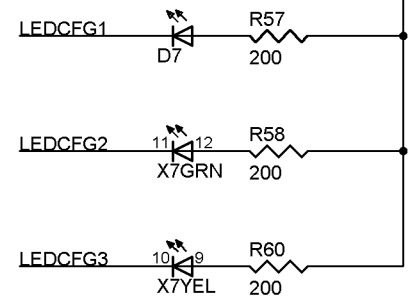
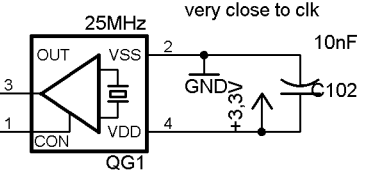
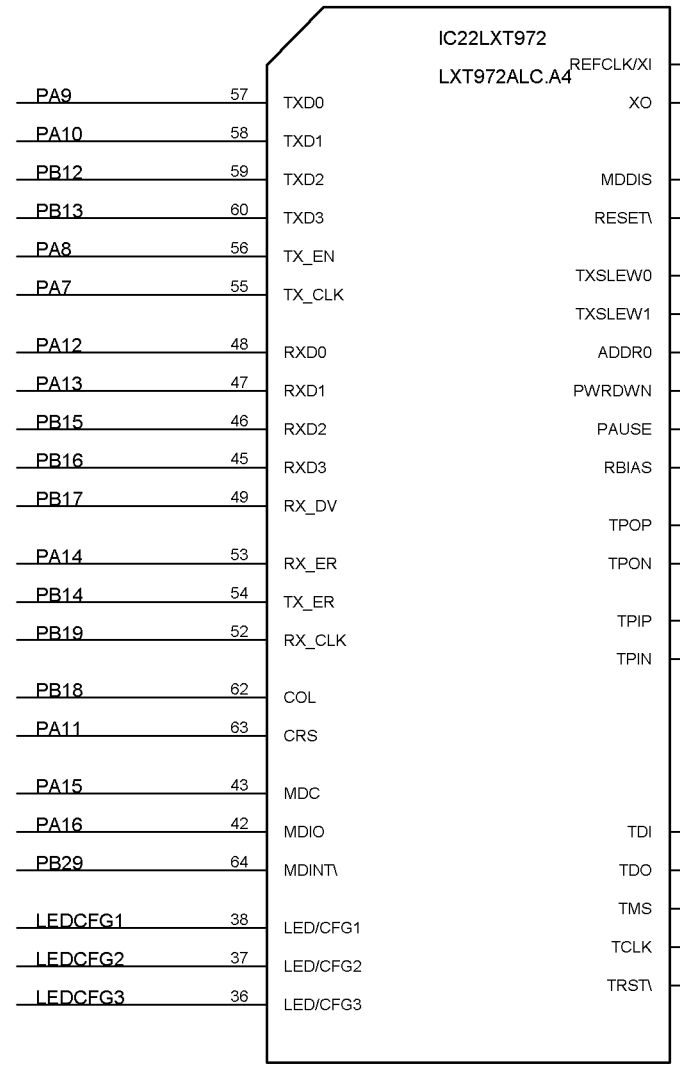
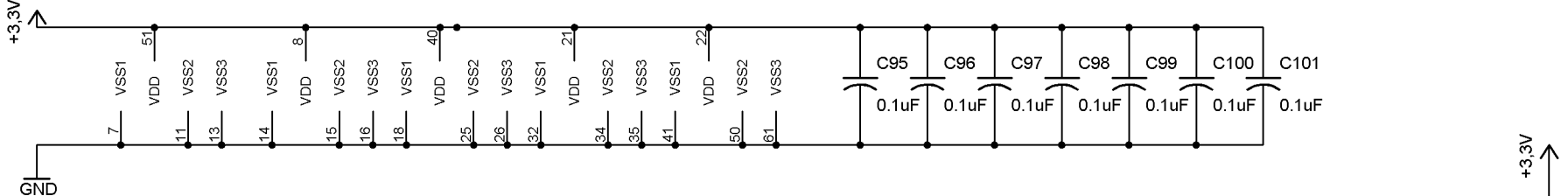

9 NC  
10 NC  
44 NC

Ethernet	
TITLE: KB9202C	
Document Number:	REV: C
Copyright 2006-2008, KwikByte (www.kwikbyte.com)	
Date: 10/07/2008 08:43:49a	Sheet: 6/6

H09042008-1.50  
KB9202C EVALUATION BOARD

SN:

© 2006

- R39
- R40
- R75
- R74
- C73
- C70
- C68
- R33

X5

R28

C55

C56

R27

IC7

R26

C54

C65

JP9

R31

C66

R32

R69

IC16

KwikByte © 2008

www.kwikbyte.com

